



# SGM4575

## 4-Bit Fixed Direction Voltage-Level Translator with Schmitt-Trigger Inputs and 3-State Outputs

### GENERAL DESCRIPTION

The SGM4575 series are 4-bit, dual-supply non-inverting fixed direction voltage-level translators. The A and B ports track the  $V_{CCA}$  supply and  $V_{CCB}$  supply respectively. The supply voltage range is from 1.1V to 5.5V for both A and B ports. The device has an output enable (OE) function, which controls the input and output states. It refers to the minimum values of  $V_{CCA}$  and  $V_{CCB}$ . The fixed direction feature allows data to transmit from A port to B port when OE goes high. When OE goes low, all I/Os enter into the high-impedance state.

The SGM4575-04 is a 4-bit, dual-supply non-inverting fixed direction voltage level translator with all 4 channels in the same direction commonly used for GPIO translation.

The SGM4575-13 is a 4-bit, dual-supply non-inverting fixed direction voltage level translator with 1 channel in the opposing direction commonly used for GPIO, SPI, and I2S translation.

The SGM4575-22 is a 4-bit, dual-supply non-inverting fixed direction voltage level translator with 2 channels in the opposing direction commonly used for GPIO, UART, and JTAG translation.

The SGM4575-04, SGM4575-13 and SGM4575-22 are available in Green TQFN-2.5×3-14L, XTQFN-1×1.7-12L, TSSOP-14 and UTQFN-1.7×2-12L packages and is rated over the -40°C to +125°C temperature range.

### APPLICATIONS

General I/O Level Shifting  
 Push-Pull Level Shifting (Like UART, SPI, JTAG)  
 Battery Powered Equipment  
 Industrial Equipment  
 Medical Equipment  
 Telecom Equipment

### FEATURES

- $V_{CCA}$  Supply Voltage Range: 1.1V to 5.5V
- $V_{CCB}$  Supply Voltage Range: 1.1V to 5.5V
- Inputs Accept Voltages Higher than the Supply Voltage and up to 5.5V
- Up to 200Mbps (TYP) Supporting for 3.3V to 5.0V
- Low Power Consumption
  - ◆ 1.61μA (TYP) at +25°C
- Slow and Noisy Input are Allowed by Schmitt-Trigger Inputs
- Integrated Static Pull-Down Resistors for Inputs Help the Channels Avoid Floating
- Outputs are Disabled when  $V_{CC} \leq 100\text{mV}$  or Floating
- $I_{OFF}$  Allows Operation in Partial-Power-Down Mode
- OE with  $V_{CC\_MIN}$  Circuitry Allows for Control from Either A or B Port
- -40°C to +125°C Operating Temperature Range
- Available in Green TQFN-2.5×3-14L, XTQFN-1×1.7-12L, TSSOP-14 and UTQFN-1.7×2-12L Packages

### FUNCTION TABLE

CONTROL INPUT	PORTS		OPERATION
	INPUTS	OUTPUTS	
H	L	L	Unidirectional, non-inverting
H	H	H	Unidirectional, non-inverting
L	X	Z	Isolation

H = High Voltage Level

L = Low Voltage Level

Z = High-Impedance State

X = Don't Care.

# 4-Bit Fixed Direction Voltage-Level Translator with Schmitt-Trigger Inputs and 3-State Outputs

## SGM4575

### PACKAGE/ORDERING INFORMATION

MODEL	PACKAGE DESCRIPTION	SPECIFIED TEMPERATURE RANGE	ORDERING NUMBER	PACKAGE MARKING	PACKING OPTION
SGM4575-04	TQFN-2.5×3-14L	-40°C to +125°C	SGM4575-04XTWB14G/TR	2CMTWB XXXXX	Tape and Reel, 3000
	XTQFN-1×1.7-12L	-40°C to +125°C	SGM4575-04XXXU12G/TR	02 XX	Tape and Reel, 4000
	TSSOP-14	-40°C to +125°C	SGM4575-04XTS14G/TR	SGM2CN XTS14 XXXXX	Tape and Reel, 4000
	UTQFN-1.7×2-12L	-40°C to +125°C	SGM4575-04XURF12G/TR	2CO XXXX	Tape and Reel, 3000
SGM4575-13	TQFN-2.5×3-14L	-40°C to +125°C	SGM4575-13XTWB14G/TR	2CPTWB XXXXX	Tape and Reel, 3000
	XTQFN-1×1.7-12L	-40°C to +125°C	SGM4575-13XXXU12G/TR	01 XX	Tape and Reel, 4000
	TSSOP-14	-40°C to +125°C	SGM4575-13XTS14G/TR	SGM2CQ XTS14 XXXXX	Tape and Reel, 4000
	UTQFN-1.7×2-12L	-40°C to +125°C	SGM4575-13XURF12G/TR	25R XXXX	Tape and Reel, 3000
SGM4575-22	TQFN-2.5×3-14L	-40°C to +125°C	SGM4575-22XTWB14G/TR	25PTWB XXXXX	Tape and Reel, 3000
	XTQFN-1×1.7-12L	-40°C to +125°C	SGM4575-22XXXU12G/TR	00 XX	Tape and Reel, 4000
	TSSOP-14	-40°C to +125°C	SGM4575-22XTS14G/TR	SGM25N XTS14 XXXXX	Tape and Reel, 4000
	UTQFN-1.7×2-12L	-40°C to +125°C	SGM4575-22XURF12G/TR	25Q XXXX	Tape and Reel, 3000

### MARKING INFORMATION

NOTE: XX = Date Code. XXXX = Date Code, Trace Code and Vendor Code. XXXXX = Date Code, Trace Code and Vendor Code.

#### TQFN-2.5×3-14L/TSSOP-14

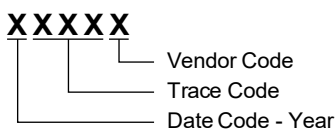

#### XTQFN-1×1.7-12L

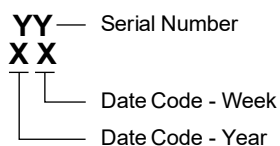

#### UTQFN-1.7×2-12L

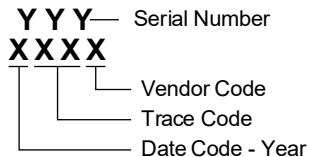

Green (RoHS & HSF): SG Micro Corp defines "Green" to mean Pb-Free (RoHS compatible) and free of halogen substances. If you have additional comments or questions, please contact your SGMICRO representative directly.

**ABSOLUTE MAXIMUM RATINGS**

Supply Voltage A, $V_{CCA}$ .....	-0.5V to 6.5V
Supply Voltage B, $V_{CCB}$ .....	-0.5V to 6.5V
Input Voltage, $V_i$ <sup>(1)</sup>	
A or B Ports.....	-0.5V to 6.5V
OE.....	-0.5V to 6.5V
Output Voltage, $V_o$ <sup>(1)(2)</sup>	
3-State Mode .....	-0.5V to 6.5V
Active Mode .....	-0.5V to $V_{CCO} + 0.5V$
Input Clamp Current, $I_{IK}$ , $V_{IN} < 0V$ .....	-20mA
Output Clamp Current, $I_{OK}$ , $V_{OUT} < 0V$ .....	-20mA
Continuous Output Current, $I_o$ .....	$\pm 25mA$
Continuous Current through $V_{CC}$ or GND, $I_o$ .....	$\pm 100mA$
Junction Temperature <sup>(3)</sup> .....	+150°C
Storage Temperature Range .....	-65°C to +150°C
Lead Temperature (Soldering, 10s).....	+260°C

**NOTES:**

1. The input and output voltage ratings may be exceeded if the input and output clamp current ratings are observed.
2.  $V_{CCO}$  is the supply voltage associated with the data output port.
3. The performance capability of a high-performance integrated circuit in conjunction with its thermal environment can create junction temperatures which are detrimental to reliability.

**RECOMMENDED OPERATING CONDITIONS**

Supply Voltage A, $V_{CCA}$ .....	1.1V to 5.5V
Supply Voltage B, $V_{CCB}$ .....	1.1V to 5.5V
Input Voltage, $V_i$ .....	0V to 5.5V
Output Voltage, $V_o$	
Active Mode .....	0V to $V_{CCO}$
3-State Mode .....	0V to 5.5V
Operating Ambient Temperature Range.....	-40°C to +125°C

**OVERSTRESS CAUTION**

Stresses beyond those listed in Absolute Maximum Ratings may cause permanent damage to the device. Exposure to absolute maximum rating conditions for extended periods may affect reliability. Functional operation of the device at any conditions beyond those indicated in the Recommended Operating Conditions section is not implied.

**ESD SENSITIVITY CAUTION**

This integrated circuit can be damaged if ESD protections are not considered carefully. SGMICRO recommends that all integrated circuits be handled with appropriate precautions. Failure to observe proper handling and installation procedures can cause damage. ESD damage can range from subtle performance degradation to complete device failure. Precision integrated circuits may be more susceptible to damage because even small parametric changes could cause the device not to meet the published specifications.

**DISCLAIMER**

SG Micro Corp reserves the right to make any change in circuit design, or specifications without prior notice.

# 4-Bit Fixed Direction Voltage-Level Translator with Schmitt-Trigger Inputs and 3-State Outputs

**SGM4575**

## PIN CONFIGURATIONS OF SGM4575-04

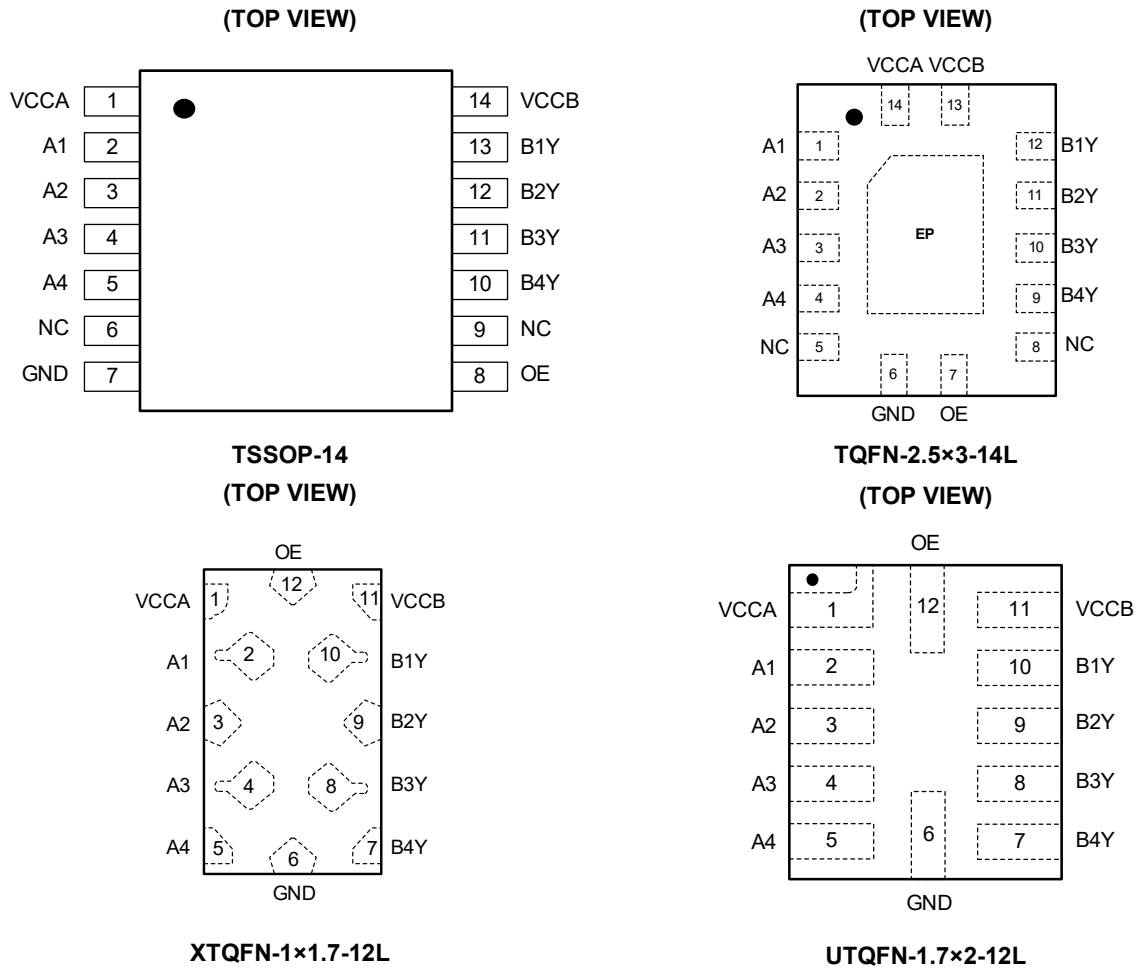

## PIN DESCRIPTION

PIN		NAME	I/O	FUNCTION
XTQFN-1x1.7-12L, UTQFN-1.7x2-12L	TSSOP-14, TQFN-2.5x3-14L			
1	1	VCCA	-	Supply Voltage on A Port. $1.1V \leq V_{CCA} \leq 5.5V$ .
2	2	A1	I	Input A1. It tracks the $V_{CCA}$ supply.
3	3	A2	I	Input A2. It tracks the $V_{CCA}$ supply.
4	4	A3	I	Input A3. It tracks the $V_{CCA}$ supply.
5	5	A4	I	Input A4. It tracks the $V_{CCA}$ supply.
6	7	GND	-	Ground.
-	6, 9	NC	-	No internal connection.
7	10	B4Y	O	Output B4. It tracks the $V_{CCB}$ supply.
8	11	B3Y	O	Output B3. It tracks the $V_{CCB}$ supply.
9	12	B2Y	O	Output B2. It tracks the $V_{CCB}$ supply.
10	13	B1Y	O	Output B1. It tracks the $V_{CCB}$ supply.
11	14	VCCB	-	Supply Voltage on B Port. $1.1V \leq V_{CCB} \leq 5.5V$ .
12	8	OE	I	Output Enable Pin (Active-High).

NOTE: I = input, O = output.

# 4-Bit Fixed Direction Voltage-Level Translator with Schmitt-Trigger Inputs and 3-State Outputs

**SGM4575**

## PIN CONFIGURATIONS OF SGM4575-13

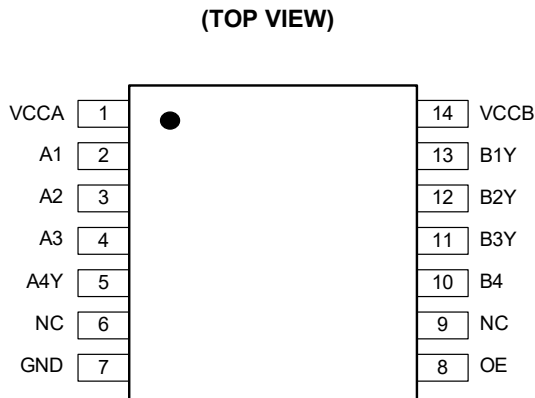

**TSSOP-14**  
(TOP VIEW)

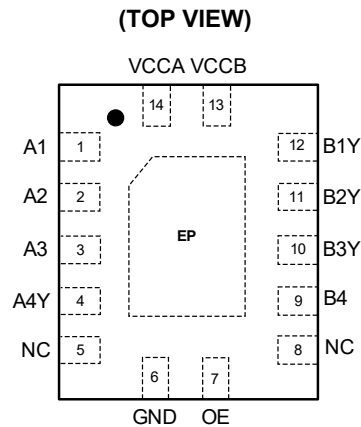

**TQFN-2.5x3-14L**  
(TOP VIEW)

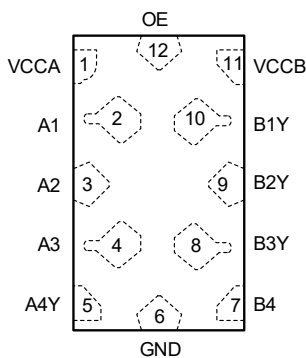

**XTQFN-1x1.7-12L**

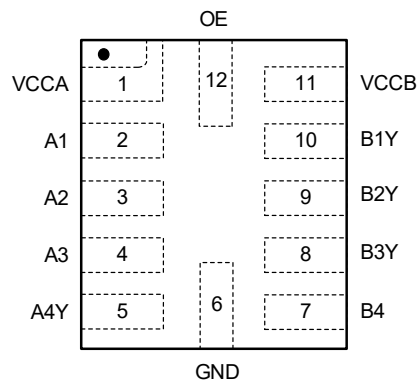

**UTQFN-1.7x2-12L**

## PIN DESCRIPTION

PIN		NAME	I/O	FUNCTION
XTQFN-1x1.7-12L, UTQFN-1.7x2-12L	TSSOP-14, TQFN-2.5x3-14L			
1	1	VCCA	-	Supply Voltage on A Port. $1.1V \leq V_{CCA} \leq 5.5V$ .
2	2	A1	I	Input A1. It tracks the $V_{CCA}$ supply.
3	3	A2	I	Input A2. It tracks the $V_{CCA}$ supply.
4	4	A3	I	Input A3. It tracks the $V_{CCA}$ supply.
5	5	A4Y	O	Output A4. It tracks the $V_{CCA}$ supply.
-	6, 9	NC	-	No internal connection.
7	10	B4	I	Input B4. It tracks the $V_{CCB}$ supply.
8	11	B3Y	O	Output B3. It tracks the $V_{CCB}$ supply.
9	12	B2Y	O	Output B2. It tracks the $V_{CCB}$ supply.
10	13	B1Y	O	Output B1. It tracks the $V_{CCB}$ supply.
11	14	VCCB	-	Supply Voltage on B Port. $1.1V \leq V_{CCB} \leq 5.5V$ .
12	8	OE	I	Output Enable Pin (Active-High).

NOTE: I = input, O = output.

# 4-Bit Fixed Direction Voltage-Level Translator with Schmitt-Trigger Inputs and 3-State Outputs

**SGM4575**

## PIN CONFIGURATIONS OF SGM4575-22

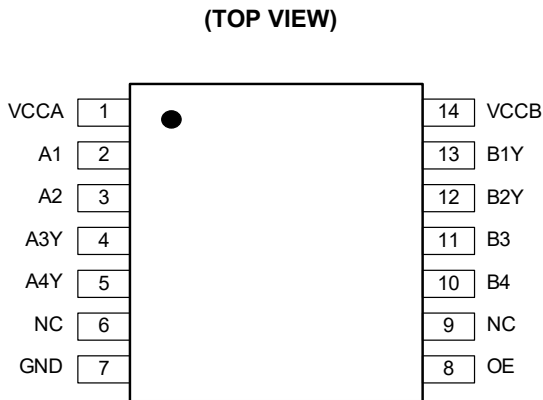

**TSSOP-14**  
(TOP VIEW)

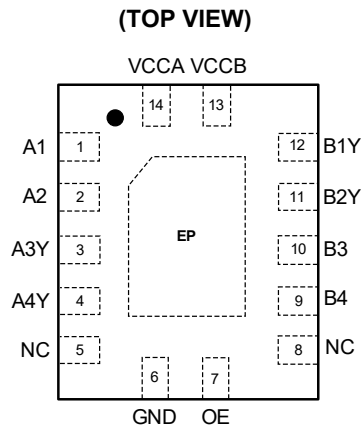

**TQFN-2.5x3-14L**  
(TOP VIEW)

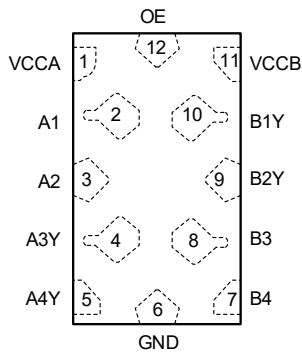

**XTQFN-1x1.7-12L**

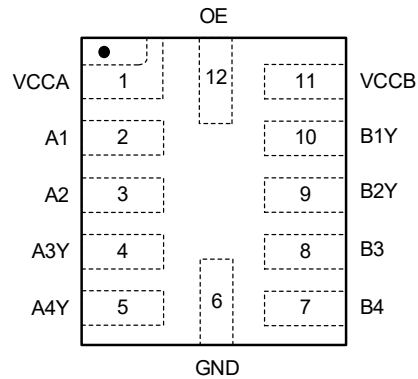

**UTQFN-1.7x2-12L**

## PIN DESCRIPTION

PIN		NAME	I/O	FUNCTION
XTQFN-1x1.7-12L, UTQFN-1.7x2-12L	TSSOP-14, TQFN-2.5x3-14L			
1	1	VCCA	-	Supply Voltage on A Port. $1.1V \leq V_{CCA} \leq 5.5V$ .
2	2	A1	I	Input A1. It tracks the $V_{CCA}$ supply.
3	3	A2	I	Input A2. It tracks the $V_{CCA}$ supply.
4	4	A3Y	O	Output A3. It tracks the $V_{CCA}$ supply.
5	5	A4Y	O	Output A4. It tracks the $V_{CCA}$ supply.
6	7	GND	-	Ground.
-	6, 9	NC	-	No internal connection.
7	10	B4	I	Input B4. It tracks the $V_{CCB}$ supply.
8	11	B3	I	Input B3. It tracks the $V_{CCB}$ supply.
9	12	B2Y	O	Output B2. It tracks the $V_{CCB}$ supply.
10	13	B1Y	O	Output B1. It tracks the $V_{CCB}$ supply.
11	14	VCCB	-	Supply Voltage on B Port. $1.1V \leq V_{CCB} \leq 5.5V$ .
12	8	OE	I	Output Enable Pin (Active-High).

NOTE: I = input, O = output.

**ELECTRICAL CHARACTERISTICS**

(Full = -40°C to +125°C, all typical values are measured at  $V_{CCI} = 5.5V$ ,  $V_{CCO} = 5.5V$  and  $T_A = +25°C$ .  $V_{CCI}$  is the supply voltage associated with the data input ports.  $V_{CCO}$  is the supply voltage associated with the data output ports, unless otherwise noted.)

PARAMETER	SYMBOL	CONDITIONS	TEMP	MIN	TYP	MAX	UNITS	
Positive-Going Input Threshold Voltage	$V_{T+}$	Data Inputs (Referenced to $V_{CCI}$ )	$V_{CCA} = 1.1V, V_{CCB} = 1.1V$	+25°C	0.44		0.88	V
			$V_{CCA} = 1.4V, V_{CCB} = 1.4V$	+25°C	0.60		0.98	
			$V_{CCA} = 1.65V, V_{CCB} = 1.65V$	+25°C	0.76		1.13	
			$V_{CCA} = 2.3V, V_{CCB} = 2.3V$	+25°C	1.08		1.56	
			$V_{CCA} = 3.0V, V_{CCB} = 3.0V$	+25°C	1.48		1.92	
			$V_{CCA} = 4.5V, V_{CCB} = 4.5V$	+25°C	2.19		2.74	
			$V_{CCA} = 5.5V, V_{CCB} = 5.5V$	+25°C	2.65		3.33	
		OE (Referenced to $V_{CCA}$ or $V_{CCB}$ )	$V_{CCA} = 1.1V, V_{CCB} = 1.1V$	+25°C	0.44		0.88	V
			$V_{CCA} = 1.4V, V_{CCB} = 1.4V$	+25°C	0.60		0.98	
			$V_{CCA} = 1.65V, V_{CCB} = 1.65V$	+25°C	0.76		1.13	
			$V_{CCA} = 2.3V, V_{CCB} = 2.3V$	+25°C	1.08		1.56	
			$V_{CCA} = 3.0V, V_{CCB} = 3.0V$	+25°C	1.48		1.92	
			$V_{CCA} = 4.5V, V_{CCB} = 4.5V$	+25°C	2.19		2.74	
			$V_{CCA} = 5.5V, V_{CCB} = 5.5V$	+25°C	2.65		3.33	
Negative-Going Input Threshold Voltage	$V_{T-}$	Data Inputs (Referenced to $V_{CCI}$ )	$V_{CCA} = 1.1V, V_{CCB} = 1.1V$	+25°C	0.17		0.48	V
			$V_{CCA} = 1.4V, V_{CCB} = 1.4V$	+25°C	0.28		0.59	
			$V_{CCA} = 1.65V, V_{CCB} = 1.65V$	+25°C	0.35		0.69	
			$V_{CCA} = 2.3V, V_{CCB} = 2.3V$	+25°C	0.56		0.97	
			$V_{CCA} = 3.0V, V_{CCB} = 3.0V$	+25°C	0.89		1.5	
			$V_{CCA} = 4.5V, V_{CCB} = 4.5V$	+25°C	1.51		1.97	
			$V_{CCA} = 5.5V, V_{CCB} = 5.5V$	+25°C	1.88		2.4	
		OE (Referenced to $V_{CCA}$ or $V_{CCB}$ )	$V_{CCA} = 1.1V, V_{CCB} = 1.1V$	+25°C	0.17		0.48	V
			$V_{CCA} = 1.4V, V_{CCB} = 1.4V$	+25°C	0.28		0.59	
			$V_{CCA} = 1.65V, V_{CCB} = 1.65V$	+25°C	0.35		0.69	
			$V_{CCA} = 2.3V, V_{CCB} = 2.3V$	+25°C	0.56		0.97	
			$V_{CCA} = 3.0V, V_{CCB} = 3.0V$	+25°C	0.89		1.5	
			$V_{CCA} = 4.5V, V_{CCB} = 4.5V$	+25°C	1.51		1.97	
			$V_{CCA} = 5.5V, V_{CCB} = 5.5V$	+25°C	1.88		2.46	
Input-Threshold Hysteresis ( $V_{T+} - V_{T-}$ )	$\Delta V_T$	Data Inputs (Referenced to $V_{CCI}$ )	$V_{CCA} = 1.1V, V_{CCB} = 1.1V$	+25°C	0.2		0.4	V
			$V_{CCA} = 1.4V, V_{CCB} = 1.4V$	+25°C	0.25		0.5	
			$V_{CCA} = 1.65V, V_{CCB} = 1.65V$	+25°C	0.3		0.55	
			$V_{CCA} = 2.3V, V_{CCB} = 2.3V$	+25°C	0.38		0.65	
			$V_{CCA} = 3.0V, V_{CCB} = 3.0V$	+25°C	0.46		0.72	
			$V_{CCA} = 4.5V, V_{CCB} = 4.5V$	+25°C	0.58		0.93	
			$V_{CCA} = 5.5V, V_{CCB} = 5.5V$	+25°C	0.69		1.06	
		OE (Referenced to $V_{CCA}$ or $V_{CCB}$ )	$V_{CCA} = 1.1V, V_{CCB} = 1.1V$	+25°C	0.15		0.41	V
			$V_{CCA} = 1.4V, V_{CCB} = 1.4V$	+25°C	0.2		0.5	
			$V_{CCA} = 1.65V, V_{CCB} = 1.65V$	+25°C	0.23		0.55	
			$V_{CCA} = 2.3V, V_{CCB} = 2.3V$	+25°C	0.32		0.65	
			$V_{CCA} = 3.0V, V_{CCB} = 3.0V$	+25°C	0.39		0.72	
			$V_{CCA} = 4.5V, V_{CCB} = 4.5V$	+25°C	0.57		0.97	
			$V_{CCA} = 5.5V, V_{CCB} = 5.5V$	+25°C	0.69		1.18	

**ELECTRICAL CHARACTERISTICS (continued)**

(Full = -40°C to +125°C, all typical values are measured at V<sub>CCI</sub> = 5.5V, V<sub>CCO</sub> = 5.5V and T<sub>A</sub> = +25°C. V<sub>CCI</sub> is the supply voltage associated with the data input ports. V<sub>CCO</sub> is the supply voltage associated with the data output ports, unless otherwise noted.)

PARAMETER	SYMBOL	CONDITIONS	TEMP	MIN	TYP	MAX	UNITS
High-Level Output Voltage	V <sub>OH</sub>	I <sub>OH</sub> = -0.1mA, V <sub>CCO</sub> = 1.1V to 5.5V	+25°C		V <sub>CCO</sub> - 0.01		V
		I <sub>OH</sub> = -0.5mA, V <sub>CCO</sub> = 1.1V	+25°C		1.08		
		I <sub>OH</sub> = -3mA, V <sub>CCO</sub> = 1.4V	+25°C		1.36		
		I <sub>OH</sub> = -4.5mA, V <sub>CCO</sub> = 1.65V	+25°C		1.55		
		I <sub>OH</sub> = -8mA, V <sub>CCO</sub> = 2.3V	+25°C		2.18		
		I <sub>OH</sub> = -10mA, V <sub>CCO</sub> = 3.0V	+25°C		2.88		
		I <sub>OH</sub> = -12mA, V <sub>CCO</sub> = 4.5V	+25°C		4.39		
Low-Level Output Voltage	V <sub>OL</sub>	I <sub>OL</sub> = 0.1mA, V <sub>CCO</sub> = 1.1V to 5.5V	+25°C		0.01		V
		I <sub>OL</sub> = 0.5mA, V <sub>CCO</sub> = 1.1V	+25°C		0.02		
		I <sub>OL</sub> = 3mA, V <sub>CCO</sub> = 1.4V	+25°C		0.07		
		I <sub>OL</sub> = 4.5mA, V <sub>CCO</sub> = 1.65V	+25°C		0.09		
		I <sub>OL</sub> = 8mA, V <sub>CCO</sub> = 2.3V	+25°C		0.12		
		I <sub>OL</sub> = 10mA, V <sub>CCO</sub> = 3.0V	+25°C		0.12		
		I <sub>OL</sub> = 8mA, V <sub>CCO</sub> = 4.5V	+25°C		0.08		
		I <sub>OL</sub> = 12mA, V <sub>CCO</sub> = 4.5V	+25°C		0.12		
Input Leakage Current	I <sub>I</sub>	OE, V <sub>I</sub> = V <sub>CC</sub> or GND	V <sub>CCA</sub> = 1.1V to 5.5V, V <sub>CCB</sub> = 1.1V to 5.5V	+25°C	1.0		μA
		Data Inputs (Ax, Bx) V <sub>I</sub> = V <sub>CCI</sub> or GND	V <sub>CCA</sub> = 1.1V to 5.5V, V <sub>CCB</sub> = 1.1V to 5.5V	+25°C	1.0		
Partial Power Down Current	I <sub>OFF</sub>	A or B Output Ports, V <sub>I</sub> or V <sub>O</sub> = 0V or 5.5V	V <sub>CCA</sub> = 0V, V <sub>CCB</sub> = 1.1V to 5.5V	+25°C	1.0		μA
			V <sub>CCA</sub> = 1.1V to 5.5V, V <sub>CCB</sub> = 0V	+25°C	1.0		
Floating Supply Partial Power Down Current <sup>(1)</sup>	I <sub>OFF_FLOAT</sub>	A or B Output Ports, V <sub>I</sub> or V <sub>O</sub> = GND	V <sub>CCA</sub> floating, V <sub>CCB</sub> = 1.1V to 5.5V	+25°C	±0.01		μA
			V <sub>CCB</sub> floating, V <sub>CCA</sub> = 1.1V to 5.5V	+25°C	±0.01		
Tri-State Output Current	I <sub>OZ</sub>	A or B Output Ports, V <sub>I</sub> = 0V or V <sub>CCI</sub> , V <sub>O</sub> = 0V or V <sub>CCO</sub>	OE = 0V, V <sub>CCA</sub> = 1.1V to 5.5V, V <sub>CCB</sub> = 1.1V to 5.5V	+25°C	±0.01		μA
			V <sub>CCA</sub> = 0V, V <sub>CCB</sub> = 1.1V to 5.5V	+25°C	±0.01		
			V <sub>CCB</sub> = 0V, V <sub>CCA</sub> = 1.1V to 5.5V	+25°C	±0.01		
Supply Current SGM4575-04	I <sub>CCA</sub>	V <sub>I</sub> = V <sub>CCI</sub> or GND, I <sub>O</sub> = 0	V <sub>CCA</sub> = 1.1V to 5.5V, V <sub>CCB</sub> = 1.1V to 5.5V	+25°C	TBD		μA
			V <sub>CCA</sub> = 0V, V <sub>CCB</sub> = 5.5V	+25°C	TBD		
			V <sub>CCA</sub> = 5.5V, V <sub>CCB</sub> = 0V	+25°C	TBD		
			V <sub>CCA</sub> = 5.5V, V <sub>CCB</sub> floating	+25°C	TBD		
	I <sub>CCB</sub>	V <sub>I</sub> = V <sub>CCI</sub> or GND, I <sub>O</sub> = 0	V <sub>CCA</sub> = 1.1V to 5.5V, V <sub>CCB</sub> = 1.1V to 5.5V	+25°C	TBD		
			V <sub>CCA</sub> = 0V, V <sub>CCB</sub> = 5.5V	+25°C	TBD		
			V <sub>CCA</sub> = 5.5V, V <sub>CCB</sub> = 0V	+25°C	TBD		
			V <sub>CCA</sub> floating, V <sub>CCB</sub> = 5.5V	+25°C	TBD		
	I <sub>CCA</sub> + I <sub>CCB</sub>	V <sub>I</sub> = V <sub>CCI</sub> or GND, I <sub>O</sub> = 0	V <sub>CCA</sub> = 1.1V to 5.5V, V <sub>CCB</sub> = 1.1V to 5.5V	+25°C	TBD		

**ELECTRICAL CHARACTERISTICS (continued)**

(Full = -40°C to +125°C, all typical values are measured at  $V_{CCI} = 5.5V$ ,  $V_{CCO} = 5.5V$  and  $T_A = +25^\circ C$ .  $V_{CCI}$  is the supply voltage associated with the data input ports.  $V_{CCO}$  is the supply voltage associated with the data output ports, unless otherwise noted.)

PARAMETER	SYMBOL	CONDITIONS	TEMP	MIN	TYP	MAX	UNITS	
Supply Current SGM4575-13	$I_{CCA}$	$V_I = V_{CCI} \text{ or GND}$ $I_O = 0$	$V_{CCA} = 1.1V \text{ to } 5.5V$ , $V_{CCB} = 1.1V \text{ to } 5.5V$	+25°C		0.63		$\mu A$
			$V_{CCA} = 0V$ , $V_{CCB} = 5.5V$	+25°C		-0.02		
			$V_{CCA} = 5.5V$ , $V_{CCB} = 0V$	+25°C		0.1		
			$V_{CCA} = 5.5V$ , $V_{CCB} \text{ floating}$	+25°C		0.1		
	$I_{CCB}$	$V_I = V_{CCI} \text{ or GND}$ $I_O = 0$	$V_{CCA} = 1.1V \text{ to } 5.5V$ , $V_{CCB} = 1.1V \text{ to } 5.5V$	+25°C		0.98		
			$V_{CCA} = 0V$ , $V_{CCB} = 5.5V$	+25°C		0.25		
			$V_{CCA} = 5.5V$ , $V_{CCB} = 0V$	+25°C		-0.02		
			$V_{CCA} \text{ floating}$ , $V_{CCB} = 5.5V$	+25°C		0.25		
	$I_{CCA} + I_{CCB}$	$V_I = V_{CCI} \text{ or GND}$ , $I_O = 0$	$V_{CCA} = 1.1V \text{ to } 5.5V$ , $V_{CCB} = 1.1V \text{ to } 5.5V$	+25°C		1.6		
	Supply Current SGM4575-22	$I_{CCA}$	$V_I = V_{CCI} \text{ or GND}$ $I_O = 0$	$V_{CCA} = 1.1V \text{ to } 5.5V$ , $V_{CCB} = 1.1V \text{ to } 5.5V$	+25°C		0.82	
$V_{CCA} = 0V$ , $V_{CCB} = 5.5V$				+25°C		-0.02		
$V_{CCA} = 5.5V$ , $V_{CCB} = 0V$				+25°C		0.1		
$V_{CCA} = 5.5V$ , $V_{CCB} \text{ floating}$				+25°C		0.1		
$I_{CCB}$		$V_I = V_{CCI} \text{ or GND}$ $I_O = 0$	$V_{CCA} = 1.1V \text{ to } 5.5V$ , $V_{CCB} = 1.1V \text{ to } 5.5V$	+25°C		0.90		
			$V_{CCA} = 0V$ , $V_{CCB} = 5.5V$	+25°C		0.26		
			$V_{CCA} = 5.5V$ , $V_{CCB} = 0V$	+25°C		-0.02		
			$V_{CCA} \text{ floating}$ , $V_{CCB} = 5.5V$	+25°C		0.26		
$I_{CCA} + I_{CCB}$		$V_I = V_{CCI} \text{ or GND}$ , $I_O = 0$	$V_{CCA} = 1.1V \text{ to } 5.5V$ , $V_{CCB} = 1.1V \text{ to } 5.5V$	+25°C		1.72		
Control Input Capacitance		$C_I$	$V_I = 3.3V \text{ or GND}$	$V_{CCA} = 3.3V$ , $V_{CCB} = 3.3V$	+25°C		5.1	pF
Data I/O Capacitance	$C_{I/O}$	OE = GND, $V_O = 1.65V$ , DC +1MHz -16dBm sine wave	$V_{CCA} = 3.3V$ , $V_{CCB} = 3.3V$	+25°C		6.2	pF	

NOTE: 1. Floating is defined as a node that is both not actively driven by an external device and has leakage not exceeding 10nA.

**DYNAMIC CHARACTERISTICS**(Full = -40°C to +125°C, all typical values are measured at T<sub>A</sub> = +25°C, unless otherwise noted.)

PARAMETER	SYMBOL	CONDITIONS	V <sub>CCB</sub>									UNITS
			1.2V ± 0.1V			1.5V ± 0.1V			1.8V ± 0.15V			
			MIN <sup>(1)</sup>	TYP	MAX <sup>(1)</sup>	MIN <sup>(1)</sup>	TYP	MAX <sup>(1)</sup>	MIN <sup>(1)</sup>	TYP	MAX <sup>(1)</sup>	
<b>V<sub>CCA</sub> = 1.2V ± 0.1V<sup>(2)</sup></b>												
Propagation Delay	t <sub>PD</sub>	A to B		13.4			10.2			8.9		ns
		B to A		13.4			12.2			11.9		
Disable Time	t <sub>DIS</sub>	OE to A		29.4			29.3			29.1		ns
		OE to B		29.6			25.6			25.5		
Enable Time	t <sub>EN</sub>	OE to A		19.3			19.1			19.2		ns
		OE to B		18.9			14.5			12.9		
<b>V<sub>CCA</sub> = 1.5V ± 0.1V<sup>(2)</sup></b>												
Propagation Delay	t <sub>PD</sub>	A to B		12.3			9.0			7.7		ns
		B to A		10.1			8.9			8.5		
Disable Time	t <sub>DIS</sub>	OE to A		21.0			20.8			20.7		ns
		OE to B		25.6			21.1			20.9		
Enable Time	t <sub>EN</sub>	OE to A		12.9			12.3			12.4		ns
		OE to B		17.0			12.2			10.5		
<b>V<sub>CCA</sub> = 1.8V ± 0.15V<sup>(2)</sup></b>												
Propagation Delay	t <sub>PD</sub>	A to B		11.9			8.5			7.2		ns
		B to A		8.8			7.7			7.2		
Disable Time	t <sub>DIS</sub>	OE to A		21.0			19.1			19.4		ns
		OE to B		25.8			19.3			19.4		
Enable Time	t <sub>EN</sub>	OE to A		10.8			9.9			9.8		ns
		OE to B		16.8			11.4			9.7		
<b>V<sub>CCA</sub> = 2.5V ± 0.2V<sup>(2)</sup></b>												
Propagation Delay	t <sub>PD</sub>	A to B		11.5			8.0			6.7		ns
		B to A		7.4			6.1			5.6		
Disable Time	t <sub>DIS</sub>	OE to A		17.6			15.9			14.8		ns
		OE to B		25.1			19.3			17.9		
Enable Time	t <sub>EN</sub>	OE to A		8.5			7.3			7.0		ns
		OE to B		16.5			11.2			9.0		
<b>V<sub>CCA</sub> = 3.3V ± 0.3V<sup>(2)</sup></b>												
Propagation Delay	t <sub>PD</sub>	A to B		11.3			7.7			6.4		ns
		B to A		6.8			5.5			5.0		
Disable Time	t <sub>DIS</sub>	OE to A		19.3			16.9			16.2		ns
		OE to B		24.9			19.2			17.4		
Enable Time	t <sub>EN</sub>	OE to A		7.7			6.4			5.8		ns
		OE to B		16.4			11.1			8.9		
<b>V<sub>CCA</sub> = 5.0V ± 0.5V<sup>(2)</sup></b>												
Propagation Delay	t <sub>PD</sub>	A to B		11.2			7.5			6.2		ns
		B to A		6.7			5.0			4.5		
Disable Time	t <sub>DIS</sub>	OE to A		16.2			14.8			13.3		ns
		OE to B		24.9			19.5			16.9		
Enable Time	t <sub>EN</sub>	OE to A		7.2			5.6			5.0		ns
		OE to B		16.4			11.1			8.8		

**DYNAMIC CHARACTERISTICS (continued)**

(Full = -40°C to +125°C, all typical values are measured at T<sub>A</sub> = +25°C, unless otherwise noted.)

PARAMETER	SYMBOL	CONDITIONS	V <sub>CCB</sub>									UNITS
			2.5V ± 0.2V			3.3V ± 0.3V			5.0V ± 0.5V			
			MIN <sup>(1)</sup>	TYP	MAX <sup>(1)</sup>	MIN <sup>(1)</sup>	TYP	MAX <sup>(1)</sup>	MIN <sup>(1)</sup>	TYP	MAX <sup>(1)</sup>	
<b>V<sub>CCA</sub> = 1.2V ± 0.1V<sup>(2)</sup></b>												
Propagation Delay	t <sub>PD</sub>	A to B		7.4			6.8			6.6		ns
		B to A		11.5			11.3			11.1		
Disable Time	t <sub>DIS</sub>	OE to A		29.4			29.4			29.5		ns
		OE to B		22.5			24.0			21.4		
Enable Time	t <sub>EN</sub>	OE to A		19.1			19.1			18.9		ns
		OE to B		11.1			10.6			10.5		
<b>V<sub>CCA</sub> = 1.5V ± 0.1V<sup>(2)</sup></b>												
Propagation Delay	t <sub>PD</sub>	A to B		6.2			5.5			5.1		ns
		B to A		8.0			7.7			7.5		
Disable Time	t <sub>DIS</sub>	OE to A		20.4			20.4			20.5		ns
		OE to B		17.4			19.2			16.3		
Enable Time	t <sub>EN</sub>	OE to A		12.3			12.4			12.3		ns
		OE to B		8.5			7.7			7.2		
<b>V<sub>CCA</sub> = 1.8V ± 0.15V<sup>(2)</sup></b>												
Propagation Delay	t <sub>PD</sub>	A to B		5.7			5.0			4.5		ns
		B to A		6.6			6.3			6.1		
Disable Time	t <sub>DIS</sub>	OE to A		19.1			19.0			18.6		ns
		OE to B		15.9			17.3			14.9		
Enable Time	t <sub>EN</sub>	OE to A		9.8			9.7			9.6		ns
		OE to B		7.5			6.7			6.1		
<b>V<sub>CCA</sub> = 2.5V ± 0.2V<sup>(2)</sup></b>												
Propagation Delay	t <sub>PD</sub>	A to B		5.1			4.4			3.9		ns
		B to A		5.0			4.7			4.5		
Disable Time	t <sub>DIS</sub>	OE to A		13.9			14.4			14.9		ns
		OE to B		14.6			15.6			12.4		
Enable Time	t <sub>EN</sub>	OE to A		6.7			6.6			6.6		ns
		OE to B		6.6			5.5			4.8		
<b>V<sub>CCA</sub> = 3.3V ± 0.3V<sup>(2)</sup></b>												
Propagation Delay	t <sub>PD</sub>	A to B		4.8			4.1			3.5		ns
		B to A		4.4			4.1			3.8		
Disable Time	t <sub>DIS</sub>	OE to A		14.9			14.8			15.5		ns
		OE to B		14.0			15.1			11.9		
Enable Time	t <sub>EN</sub>	OE to A		5.3			5.2			5.1		ns
		OE to B		6.2			5.1			4.3		
<b>V<sub>CCA</sub> = 5.0V ± 0.5V<sup>(2)</sup></b>												
Propagation Delay	t <sub>PD</sub>	A to B		4.5			3.8			3.3		ns
		B to A		3.9			3.5			3.3		
Disable Time	t <sub>DIS</sub>	OE to A		11.8			11.4			11.4		ns
		OE to B		15.3			15.4			11.6		
Enable Time	t <sub>EN</sub>	OE to A		4.3			4.0			3.9		ns
		OE to B		6.1			4.8			3.9		

NOTES:

1. Specified by design and characterization, not production tested.
2. t<sub>PD</sub> is the same as t<sub>PLH</sub> and t<sub>PHL</sub>. t<sub>DIS</sub> is the same as t<sub>PLZ</sub> and t<sub>PHZ</sub>. t<sub>EN</sub> is the same as t<sub>PZL</sub> and t<sub>PZH</sub>.

**TYPICAL POWER DISSIPATION CAPACITANCE**

(T<sub>A</sub> = +25°C, V<sub>CCA</sub> = V<sub>CCB</sub>, unless otherwise noted.)

PARAMETER	SYMBOL	CONDITIONS	V <sub>CCA</sub> = V <sub>CCB</sub>						UNITS	
			1.2V ± 0.1V	1.5V ± 0.1V	1.8V ± 0.15V	2.5V ± 0.2V	3.3V ± 0.3V	5.0V ± 0.5V		
Power Dissipation Capacitance <sup>(1)</sup>	C <sub>PDA</sub>	A Port, C <sub>L</sub> = 0, R <sub>L</sub> = Open f = 10MHz t <sub>RISE</sub> = t <sub>FALL</sub> = 1ns	A to B: outputs enabled	1	1	1	1	1	2	pF
			A to B: outputs disabled	1	1	1	1	1	2	
			B to A: outputs enabled	16	16	17	18	19	21	
			B to A: outputs disabled	2	2	2	2	2	2	
	C <sub>PDB</sub>	B Port, C <sub>L</sub> = 0, R <sub>L</sub> = Open f = 10MHz t <sub>RISE</sub> = t <sub>FALL</sub> = 1ns	A to B: outputs enabled	16	16	17	18	19	20	pF
			A to B: outputs disabled	2	2	2	2	2	2	
			B to A: outputs enabled	1	1	1	1	1	2	
			B to A: outputs disabled	1	1	1	1	1	2	

NOTE:

1. C<sub>PD</sub> is used to determine the dynamic power dissipation (P<sub>D</sub> in μW).

$$P_D = C_{PD} \times V_{CC}^2 \times f_i \times N + \sum(C_L \times V_{CC}^2 \times f_o)$$

where:

f<sub>i</sub> = Input frequency in MHz.

f<sub>o</sub> = Output frequency in MHz.

C<sub>L</sub> = Output load capacitance in pF.

V<sub>CC</sub> = Supply voltage in Volts.

N = Number of inputs switching.

∑(C<sub>L</sub> × V<sub>CC</sub><sup>2</sup> × f<sub>o</sub>) = Sum of the outputs.

# SGM4575

## 4-Bit Fixed Direction Voltage-Level Translator with Schmitt-Trigger Inputs and 3-State Outputs

### FUNCTIONAL BLOCK DIAGRAM

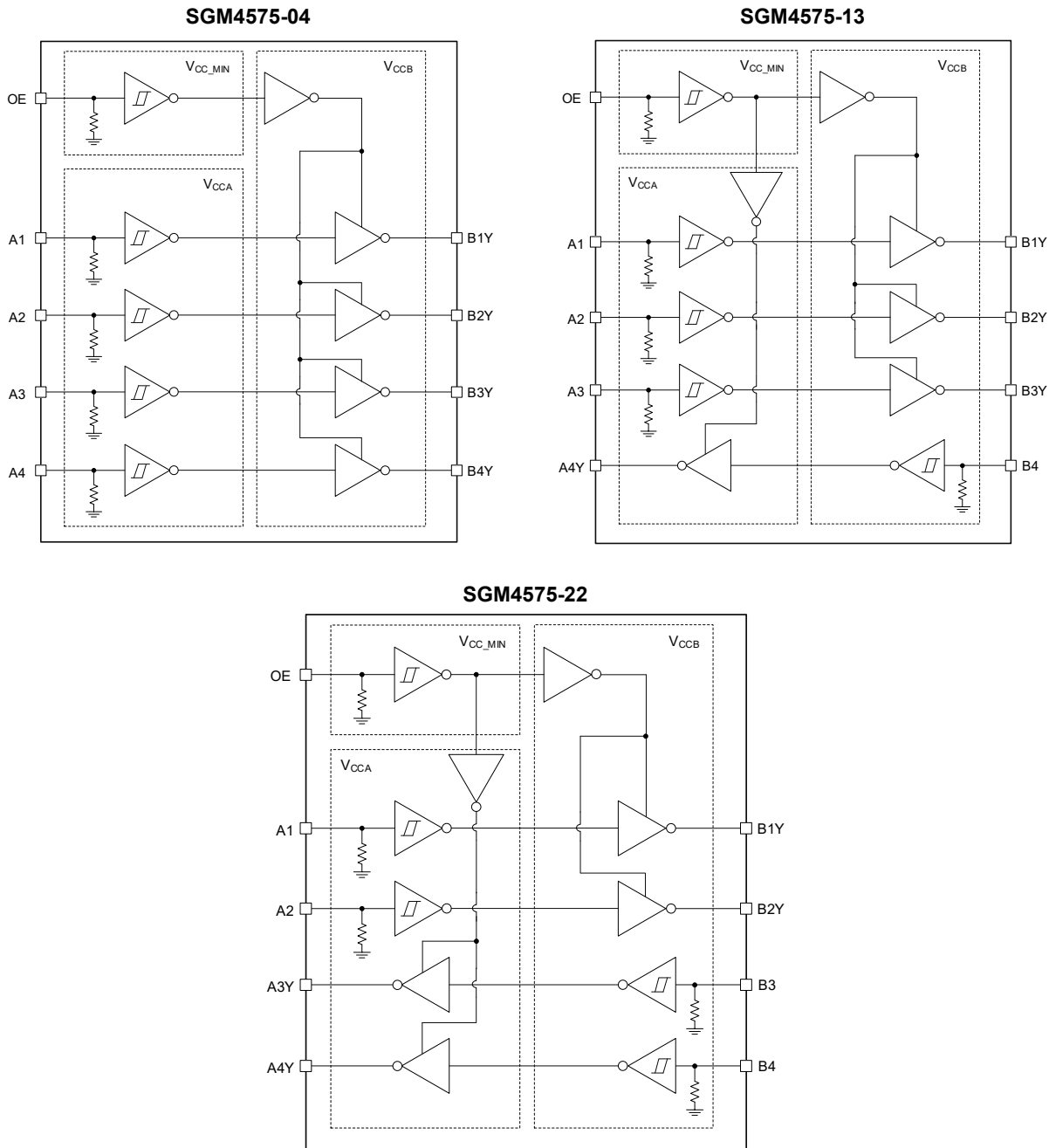
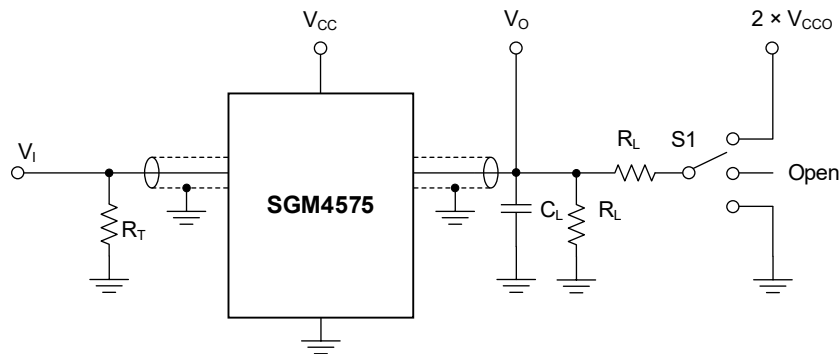

Figure 1. Block Diagram

TEST CIRCUIT



Test conditions are given in Table 1.

Definitions for test circuit:

RL: Load resistance.

CL: Load capacitance (includes jig and probe).

RT: Termination resistance (equals to output impedance ZO of the pulse generator).

S1: Test selection switch.

VEXT: External voltage used to measure switching time.

f = 1MHz, ZO = 50Ω, Δt/ΔV ≤ 1ns/V.

Figure 2. Test Circuit for Measuring Switching Times

Table 1. Test Conditions

SUPPLY VOLTAGE	INPUT		LOAD		VEXT		
VCC	VI <sup>(1)</sup>	Δt/ΔV	CL	RL	tPLH, tPHL	tPZH, tPHZ	tPZL, tPLZ <sup>(2)</sup>
1.1V to 1.6V	VCCI	≤ 1.0ns/V	5pF	10kΩ	Open	GND	2 × VCCO
1.65V to 2.7V	VCCI	≤ 1.0ns/V	5pF	10kΩ	Open	GND	2 × VCCO
3.0V to 3.6V	VCCI	≤ 1.0ns/V	5pF	10kΩ	Open	GND	2 × VCCO

NOTES:

- VCCI is the supply voltage associated with the data input ports.
- VCCO is the supply voltage associated with the data output ports.

WAVEFORMS

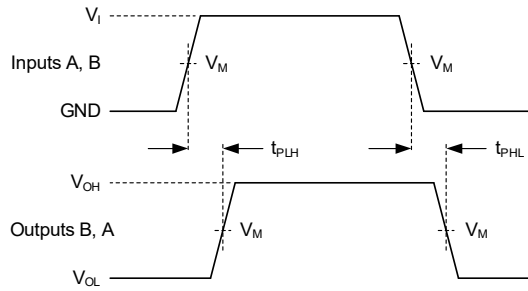

Test conditions are given in Table 1.

Measurement points are given in Table 2.

Logic levels:  $V_{OL}$  and  $V_{OH}$  are typical output voltage levels that occur with the output load.

Figure 3. Inputs (A, B) to Outputs (B, A) Propagation Delays

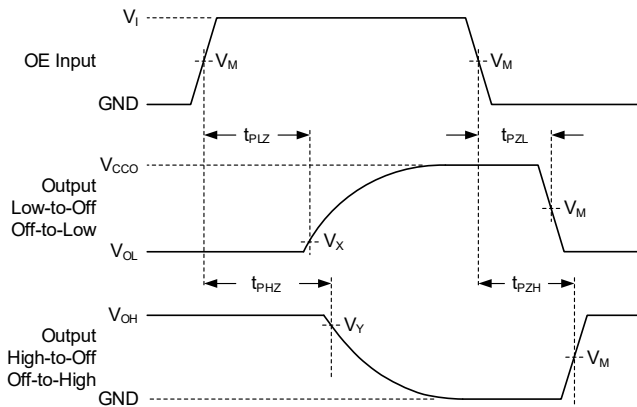

Test conditions are given in Table 1.

Measurement points are given in Table 2.

Logic levels:  $V_{OL}$  and  $V_{OH}$  are typical output voltage levels that occur with the output load.

Figure 4. Enable and Disable Times

Table 2. Measurement Points

SUPPLY VOLTAGE	INPUTS <sup>(1)</sup>		OUTPUTS		
$V_{CC}$	$V_I$	$V_M$ <sup>(2)</sup>	$V_M$ <sup>(3)</sup>	$V_X$	$V_Y$
1.1V to 1.6V	$V_{CCI}$	$0.5 \times V_{CCI}$	$0.5 \times V_{CCO}$	$V_{OL} + 0.1V$	$V_{OH} - 0.1V$
1.65V to 2.7V	$V_{CCI}$	$0.5 \times V_{CCI}$	$0.5 \times V_{CCO}$	$V_{OL} + 0.15V$	$V_{OH} - 0.15V$
3.0V to 5.5V	$V_{CCI}$	$0.5 \times V_{CCI}$	$0.5 \times V_{CCO}$	$V_{OL} + 0.3V$	$V_{OH} - 0.3V$

NOTES:

- $V_{CCI}$  is the supply voltage associated with the data input ports.
- The measurement points should be  $V_{IH}$  or  $V_{IL}$  when  $\Delta t/\Delta V > 1.0ns/V$ .
- $V_{CCO}$  is the supply voltage associated with the data output ports.

# PACKAGE INFORMATION

## PACKAGE OUTLINE DIMENSIONS

### TQFN-2.5×3-14L

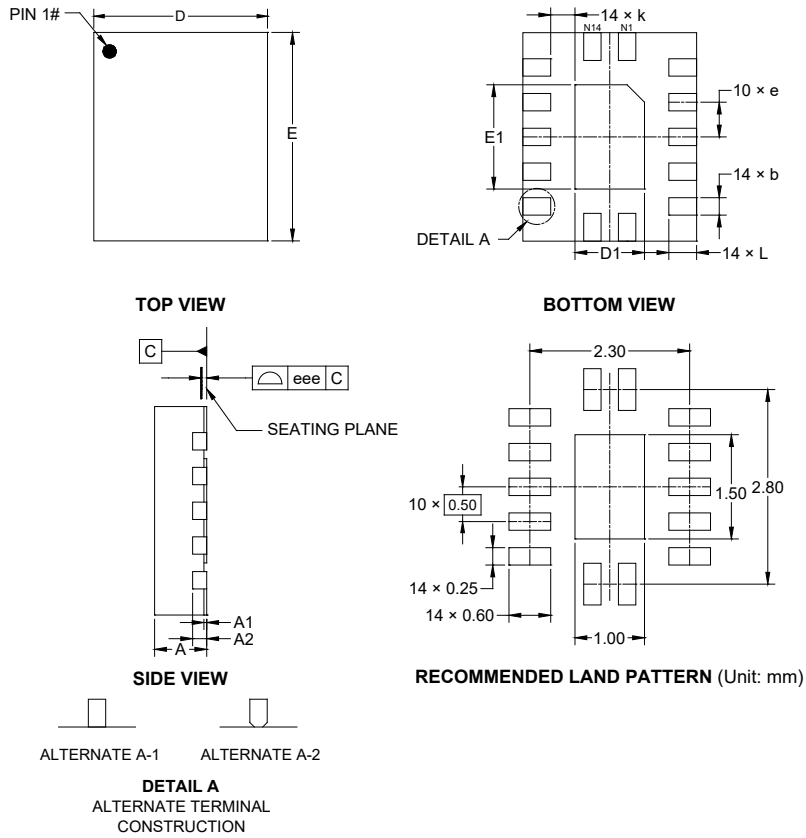

Symbol	Dimensions In Millimeters		
	MIN	NOM	MAX
A	0.700	-	0.800
A1	0.000	-	0.050
A2	0.203 REF		
b	0.200	-	0.300
D	2.400	-	2.600
D1	0.900	-	1.100
E	2.900	-	3.100
E1	1.400	-	1.600
e	0.500 BSC		
k	0.350 REF		
L	0.300	-	0.500
eee	0.080		

NOTE: This drawing is subject to change without notice.

# PACKAGE INFORMATION

## PACKAGE OUTLINE DIMENSIONS

### XTQFN-1×1.7-12L

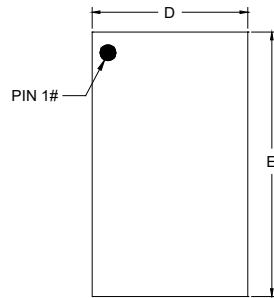

TOP VIEW

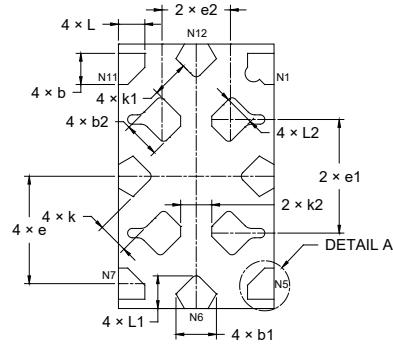

BOTTOM VIEW

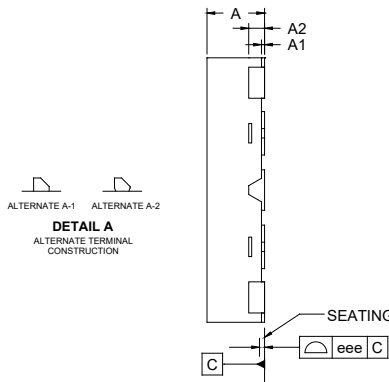

SIDE VIEW

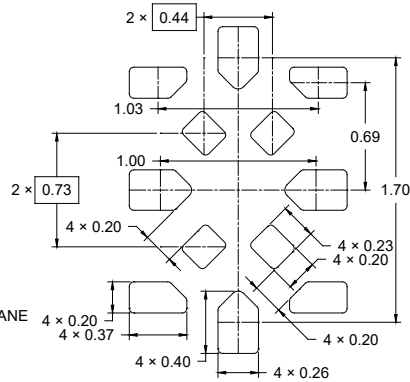

RECOMMENDED LAND PATTERN (Unit: mm)

Symbol	Dimensions In Millimeters		
	MIN	NOM	MAX
A	0.320	-	0.400
A1	0.000	-	0.050
A2	0.102 REF		
b	0.150	-	0.250
b1	0.210	-	0.310
b2	0.180	-	0.280
D	0.900	-	1.100
E	1.600	-	1.800
e	0.690 BSC		
e1	0.730 BSC		
e2	0.440 BSC		
k	0.200 REF		
k1	0.240 REF		
k2	0.200 REF		
L	0.120	-	0.220
L1	0.110	-	0.310
L2	0.150	-	0.250
eee	0.080		

NOTE: This drawing is subject to change without notice.

PACKAGE OUTLINE DIMENSIONS

TSSOP-14

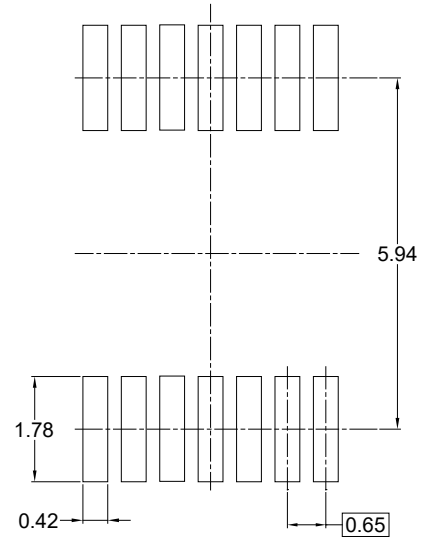
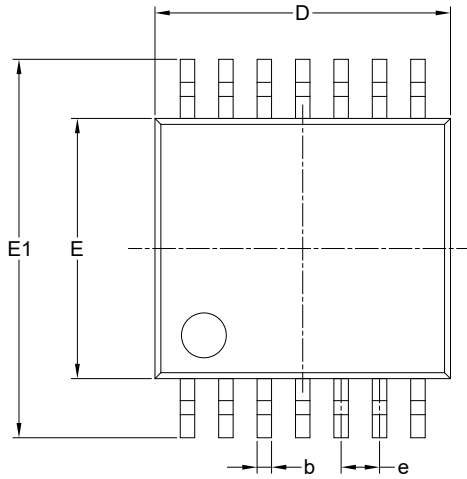

RECOMMENDED LAND PATTERN (Unit: mm)

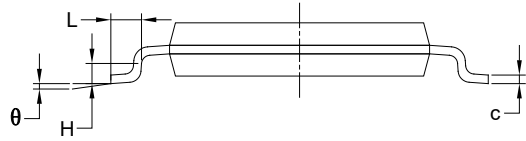
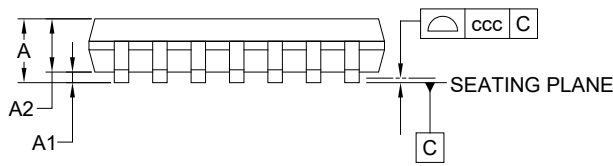

Symbol	Dimensions In Millimeters		
	MIN	NOM	MAX
A	-	-	1.200
A1	0.050	-	0.150
A2	0.800	-	1.050
b	0.190	-	0.300
c	0.090	-	0.200
D	4.860	-	5.100
E	4.300	-	4.500
E1	6.200	-	6.600
e	0.650 BSC		
L	0.450	-	0.750
H	0.250 TYP		
θ	0°	-	8°
ccc	0.100		

NOTES:

1. This drawing is subject to change without notice.
2. The dimensions do not include mold flashes, protrusions or gate burrs.
3. Reference JEDEC MO-153.

PACKAGE OUTLINE DIMENSIONS

UTQFN-1.7×2-12L

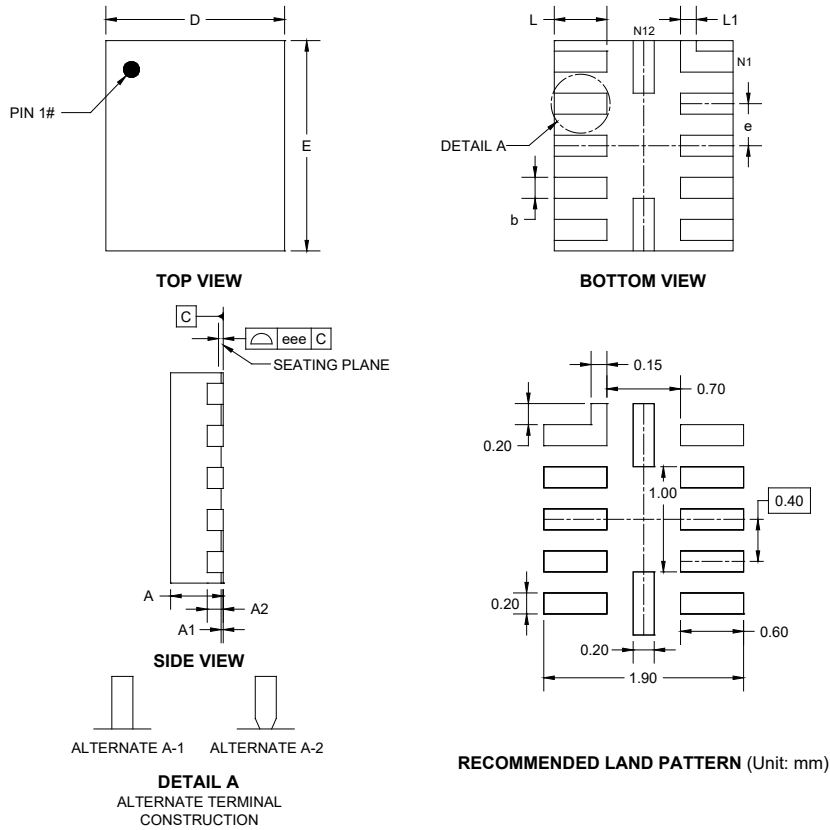

Symbol	Dimensions In Millimeters		
	MIN	NOM	MAX
A	0.450	-	0.550
A1	0.000	-	0.050
A2	0.152 REF		
b	0.150	-	0.250
D	1.600	-	1.800
E	1.900	-	2.100
e	0.400 BSC		
L	0.450	-	0.550
L1	0.150 REF		
eee	0.080		

NOTE: This drawing is subject to change without notice.

**TAPE AND REEL INFORMATION**

**REEL DIMENSIONS**

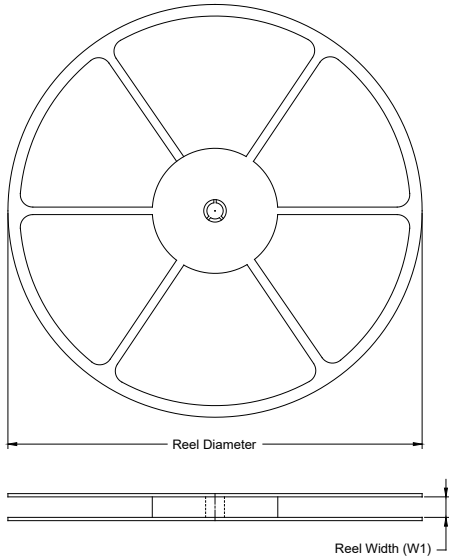

**TAPE DIMENSIONS**

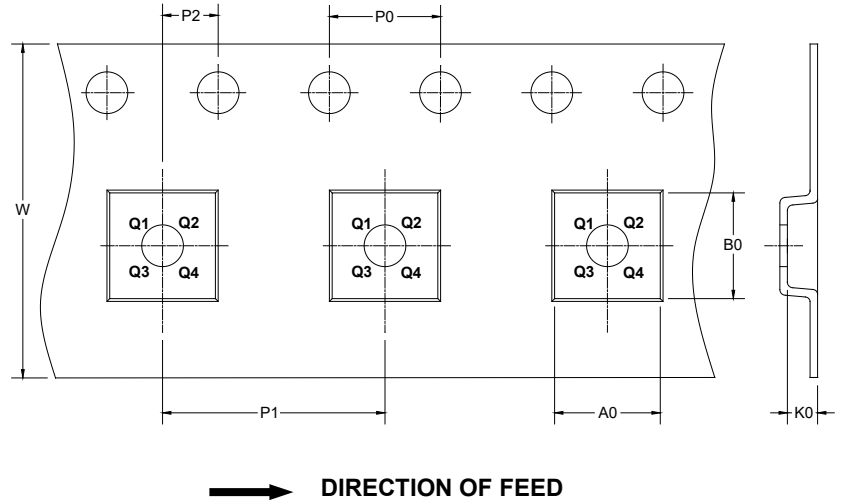

NOTE: The picture is only for reference. Please make the object as the standard.

**KEY PARAMETER LIST OF TAPE AND REEL**

Package Type	Reel Diameter	Reel Width W1 (mm)	A0 (mm)	B0 (mm)	K0 (mm)	P0 (mm)	P1 (mm)	P2 (mm)	W (mm)	Pin1 Quadrant
TQFN-2.5×3-14L	13"	12.4	2.80	3.30	1.15	4.0	4.0	2.0	12.0	Q1
XTQFN-1×1.7-12L	7"	9.5	1.19	1.82	0.54	4.0	4.0	2.0	8.0	Q1
TSSOP-14	13"	12.4	6.80	5.40	1.50	4.0	8.0	2.0	12.0	Q1
UTQFN-1.7×2-12L	7"	9.5	1.90	2.30	0.75	4.0	4.0	2.0	8.0	Q1

D00001

# PACKAGE INFORMATION

## CARTON BOX DIMENSIONS

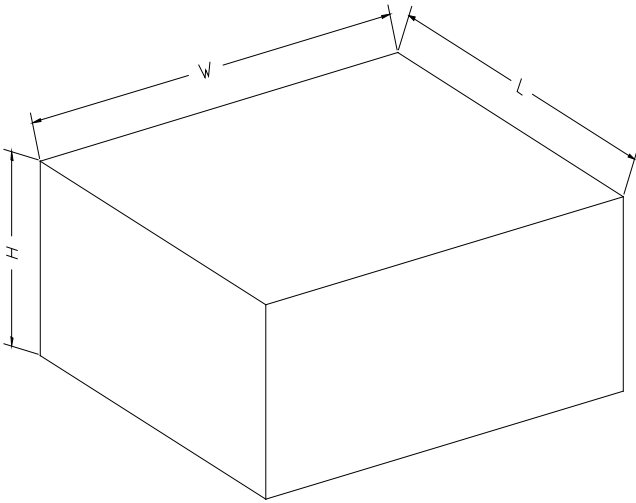

NOTE: The picture is only for reference. Please make the object as the standard.

## KEY PARAMETER LIST OF CARTON BOX

Reel Type	Length (mm)	Width (mm)	Height (mm)	Pizza/Carton
7" (Option)	368	227	224	8
7"	442	410	224	18
13"	386	280	370	5

DD0002